

# isis™

## INTELLIGENT MULTIPLEX SYSTEM

**Mastercell Section Notice**

This schematic covers the **MASTERCELL ONLY**. There are no 12V loads or 12V feeds. All wires are Mastercell switch circuits.

Application of battery voltage will result in serious damage to the ISIS system and void your warranty. See the Powercell schematics, below, for all 12V circuits and necessary switches

Mastercell Schematic color key:

- RED** = Control Circuits that are enabled with ignition on
- GREEN** = Control Circuits that are always enabled
- BLACK** = Control circuit ground connections

Refer to "Wire Assignment Reference Guide" for actual wire and tracer colors

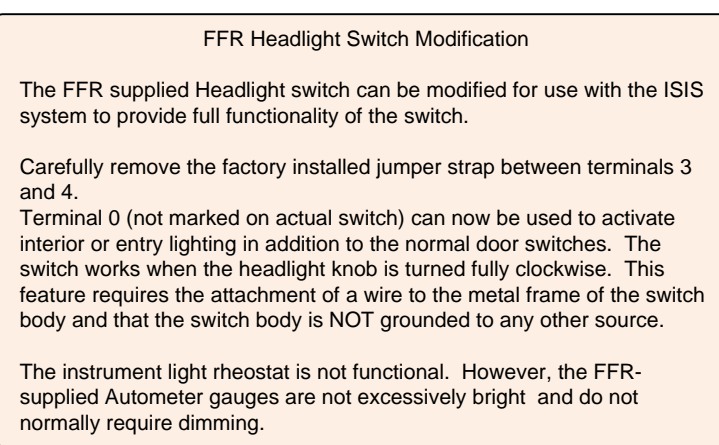
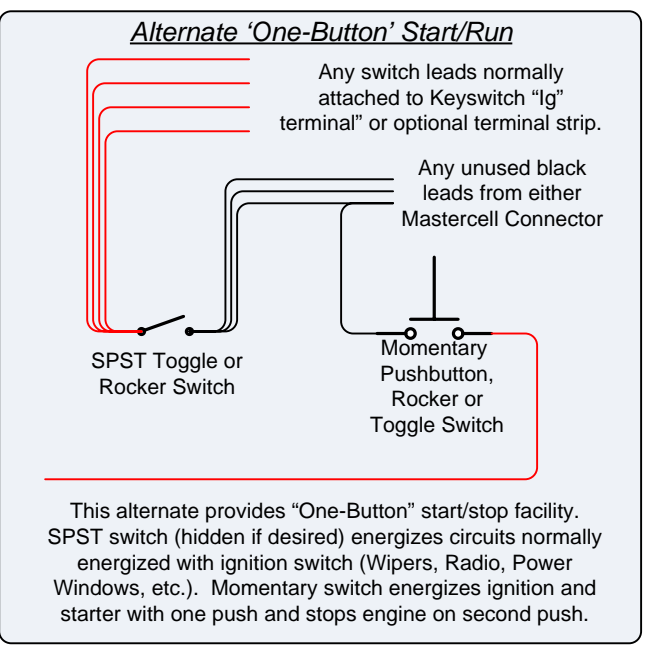

### Mastercell Control Circuits

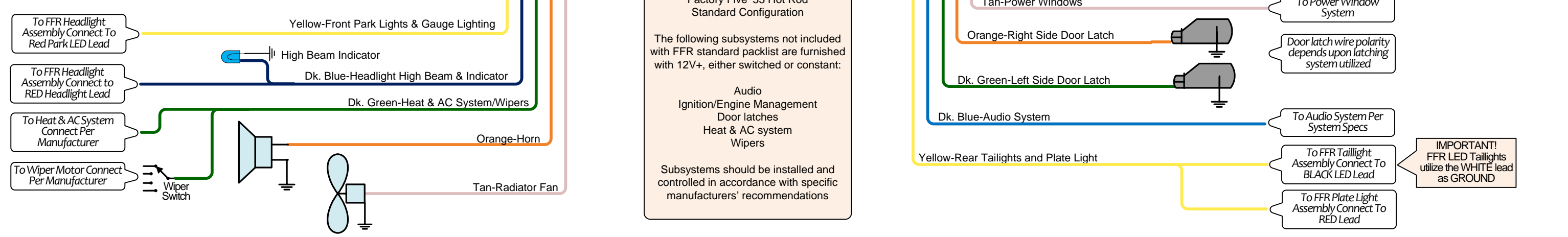
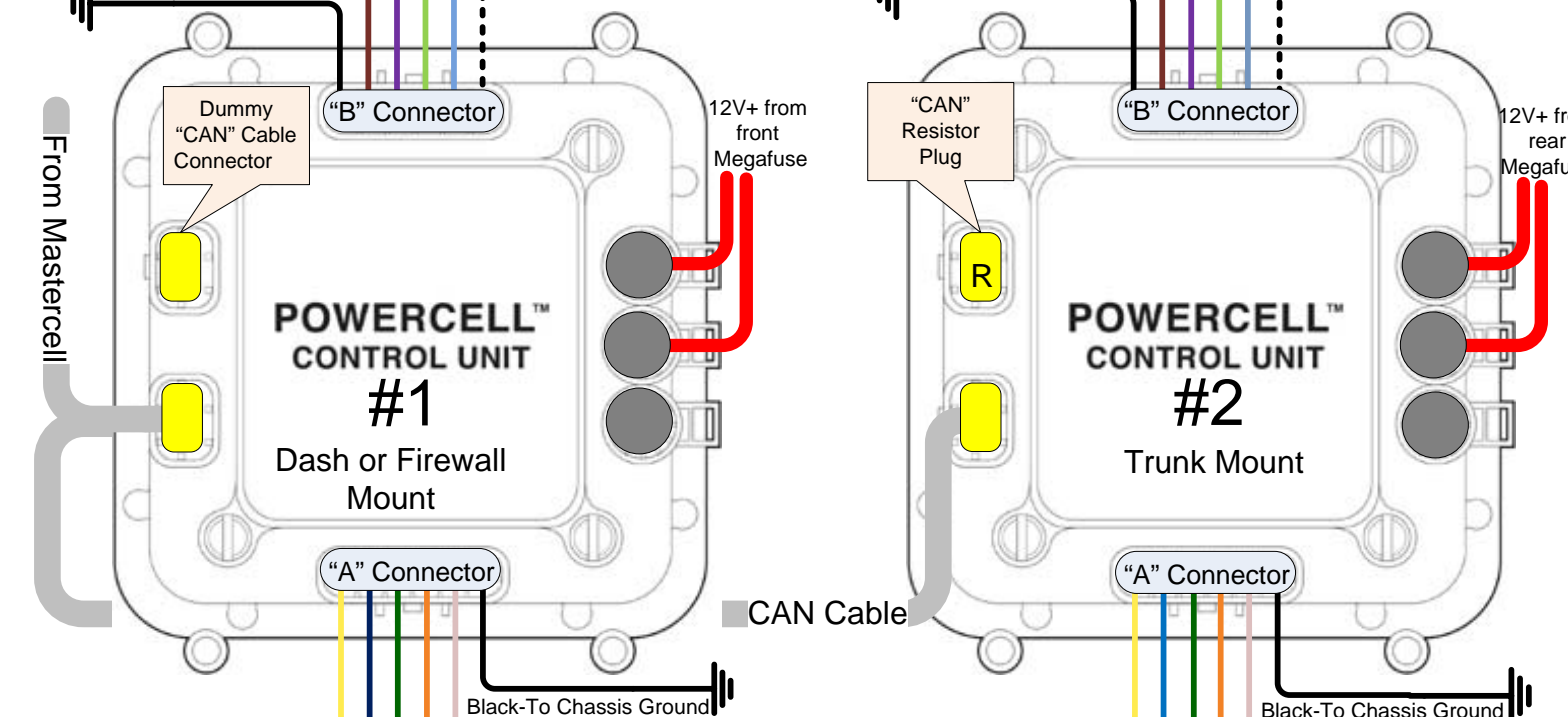
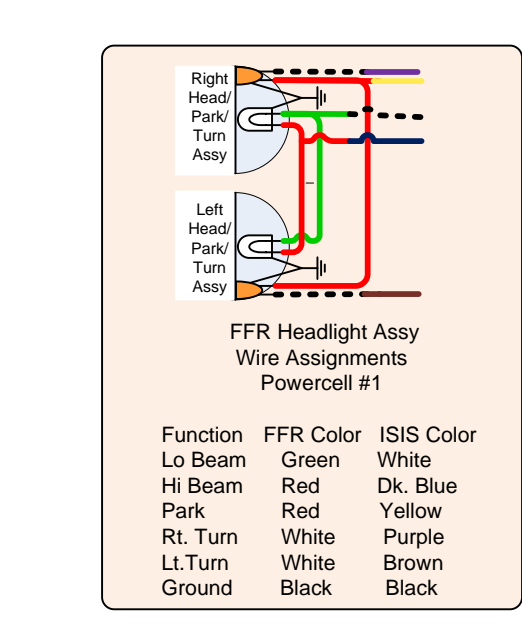
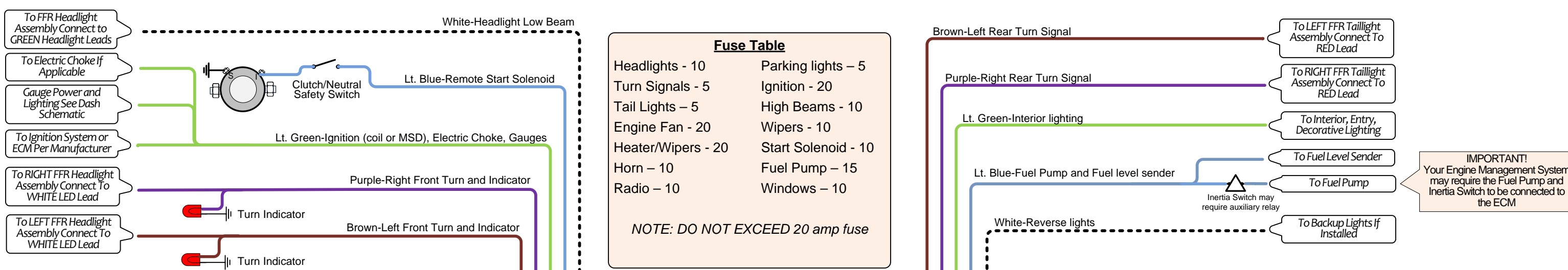

### Powercell Power Circuits

**'33 ELECTRICAL SYSTEM**

CREATED BY: JOSEPH A. LEONE, METHUEN, MASSACHUSETTS  
'33 HOT ROD CHASSIS #4 FFCOBA.COM MEMBER #86

FOR DISTRIBUTION BY LITTLEFUSE, INC., DES PLAINES, IL

**SCHEMATICS DESIGNED FOR EXCLUSIVE USE WITH FACTORY FIVE RACING '33 HOT ROD. THIS SPECIALLY PROGRAMMED ISIS SYSTEM UTILIZES ALL FACTORY FIVE SUPPLIED ELECTRICAL COMPONENTS WITH THE ADDITIONAL CAPABILITY OF PROVIDING "ONE-BUTTON START" AND OPERATING ELECTRIC DOOR LATCH ACTUATORS AND BACKUP LAMPS (ACTUATORS AND LAMPS NOT INCLUDED WITH THE ISIS SYSTEM). THEY ARE INTENDED AS A SUPPLEMENT TO, AND NOT A SUBSTITUTE FOR, THE ISIS INSTALLATION INSTRUCTIONS.**

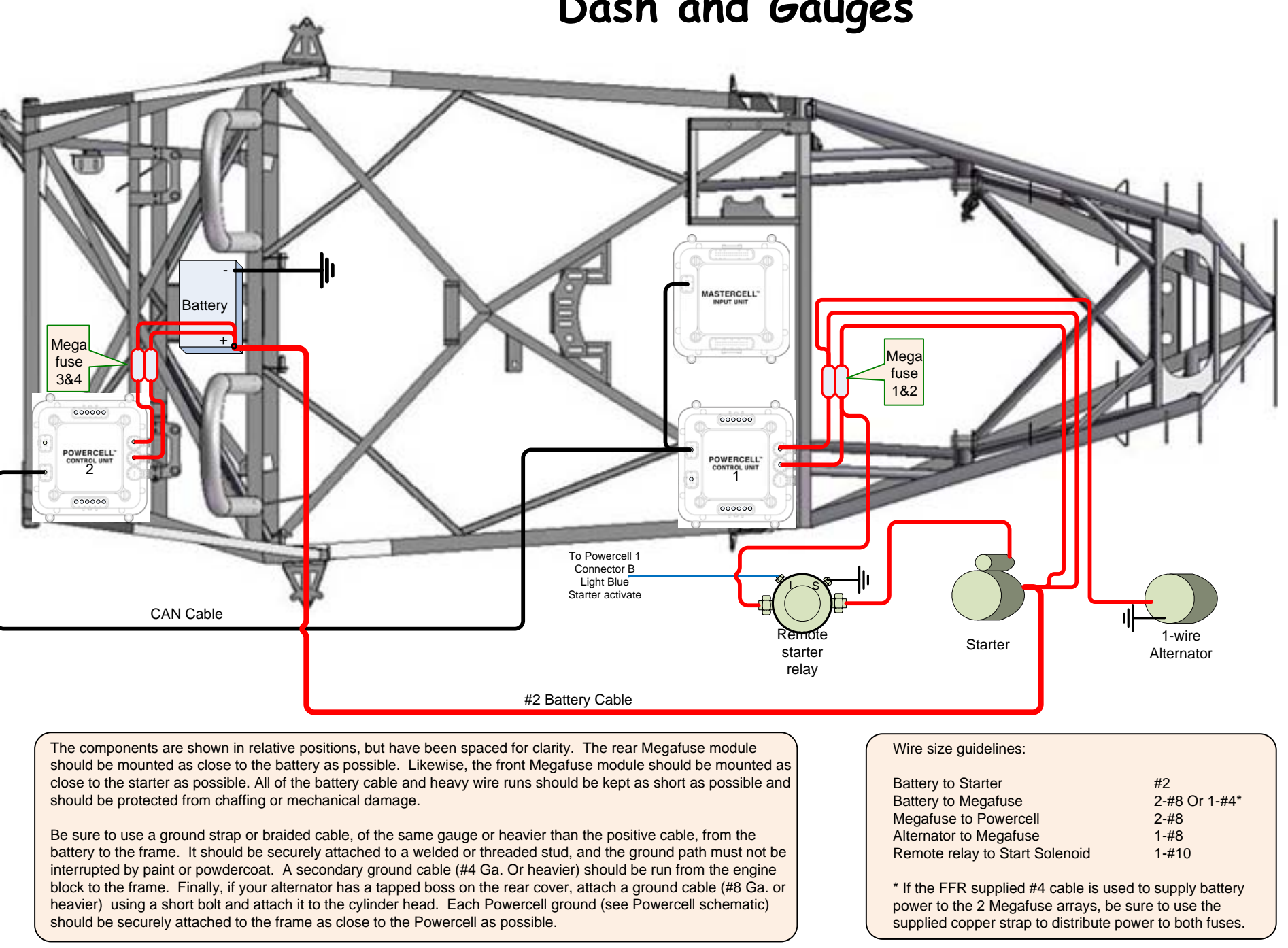
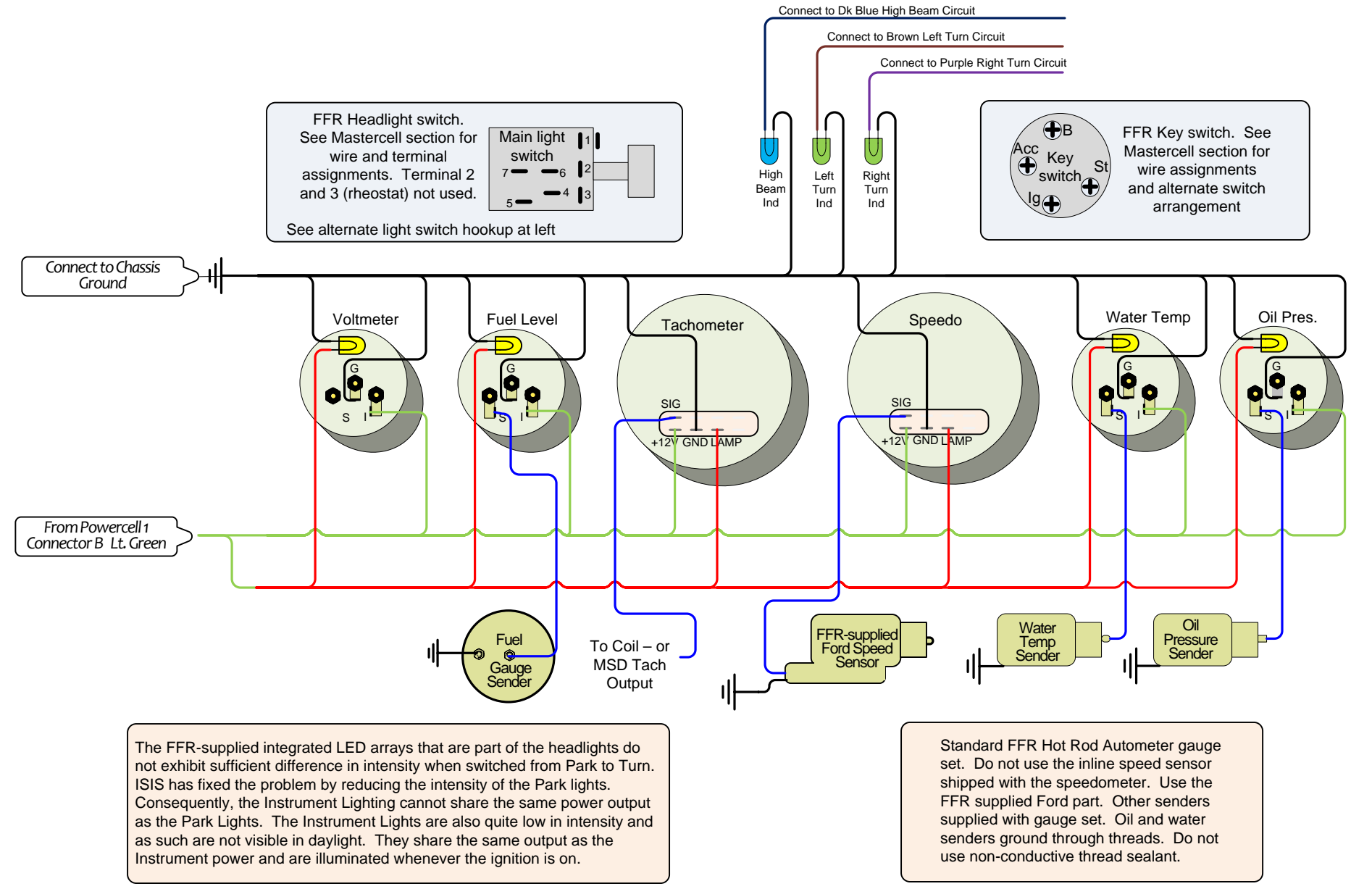
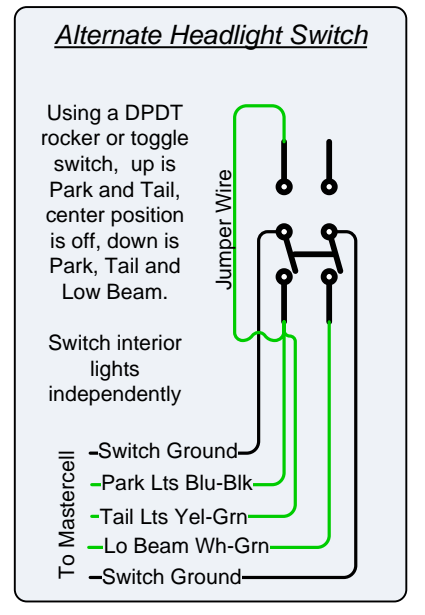

WIRE ASSIGNMENT REFERENCE CHART							
Powercell #1 Front MOUNT	Output Node Number	Output Wire Color	Constant or Ignition Controlled	Mastercell Wire Color/Main/Trace	Key Fob Assignment	Description	Notes
Connector B	1	Brown	Constant	Pink/Blue		Left Front Turn LED	Single Mastercell switch node operates front and rear turn signals
	2	Purple	Constant	Pink/Red		Right Front Turn LED	
	3	Lt. Green	Ignition	White/Blue	Page 1 Switch 1	Ignition System/Choke, Gauge Power	12V/power for ignition system. Wire system in accordance with manufacturer's specs. Also power to instruments and electric choke 12V to remote starter solenoid. Can be used with FFR keyswitch or start button. One-button ignition/start function available.
	4	Lt. Blue	Ignition	White/Yellow		Starter Activate	
	5	White	Constant	Tan/Green		Headlight Low Beam	12V to low beam headlights
Connector A	6	Yellow	Constant	Blue/Black	Page 2 Switch 2	Front Park Lights	12V/reduced power to FFR LED Park Lights
	7	Blue	Constant	Tan/Orange		Headlight High Beam/Flash To Pass	12V to high beam headlights. When headlights are off, button functions as flash-to-pass. When headlights are on, button functions to toggle high beams. Function defaults to off when headlight switch is off.
	8	Green	Ignition	Blue/Lt Blue	Page 1 Switch 4	Heat, AC, Wiper	12V to power Wipers and Heat & AC according to manufacturer's specs.
	9	Orange	Constant	Blue/Yellow	Page 1 Switch 3	Horn	12V to activate horn
	10	Tan	Constant	Blue/Green	Page 1 Switch 3	Radiator Cooling Fan	12V to activate radiator cooling fan
Powercell #2 Rear MOUNT	Output Node Number	Output Wire Color	Constant or Ignition Controlled	Mastercell Wire Color/Main/Trace	Key Fob Assignment	Description	Notes
Connector B	1	Brown	Constant	Pink/Blue		Left Rear Turn Signal	Single Mastercell switch node operates front and rear turn signals
	2	Purple	Constant	Pink/Red		Right Rear Turn Signal	
	3	Lt. Green	Constant	Pink/Green		Interior Lights	
Connector A	4	Lt. Blue	Ignition	White/Black		Fuel Pump & Sender Power	12V to fuel pump and fuel level sender, if required. Inertia switch operates through Mastercell
	5	White	Constant	White/Red		Reverse Lights	12V to reverse lights IF taillights are active
	6	Yellow	Constant	Yellow/Green		Rear Tail and Plate Lights	12V to rear taillights and License Plate Light
	7	Blue	Ignition	Tan/Black		Audio System	12V to power audio system, if installed. Wire according to manufacturer's specs
	8	Green	Constant	Tan/Red	Page 0 Switch 3	Left Side Door Latch	12V to actuate powered door latch, if installed. Doors actuate with keyfob or hidden bypass switch, as shown. actuation delivers 1-second pulse to appropriate door latch. A hidden emergency switch is recommended
	9	Orange	Constant	Tan/Blue	Page 0 Switch 4	Right Side Door Latch	12V to power window system. Wire according to manufacturer's specs
	10	Tan	Ignition	Tan/Yellow		Power Windows	12V to power window system. Wire according to manufacturer's specs
						Brake Switch	Brake switch actuates rear turn LEDs as required
						4-Way Flasher Switch	Hazard switch actuates front and rear turn LEDs as required.